

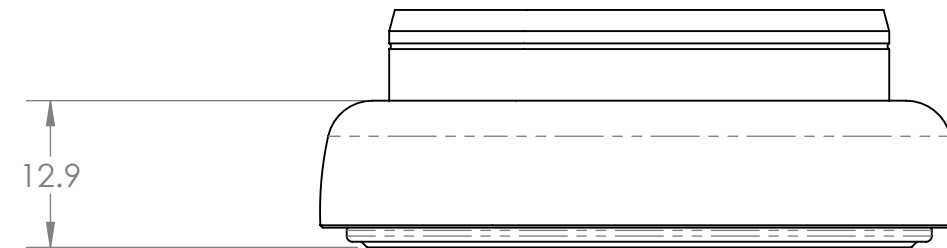

ITEM NO.	PART NUMBER	DESCRIPTION	QTY.
1	100-5005-004	HS ENVE IS52/IS52 INT Press-In Cup Set	1
2	100-5005-005	HS INT Classic IS52/IS52 w Crown Race	1

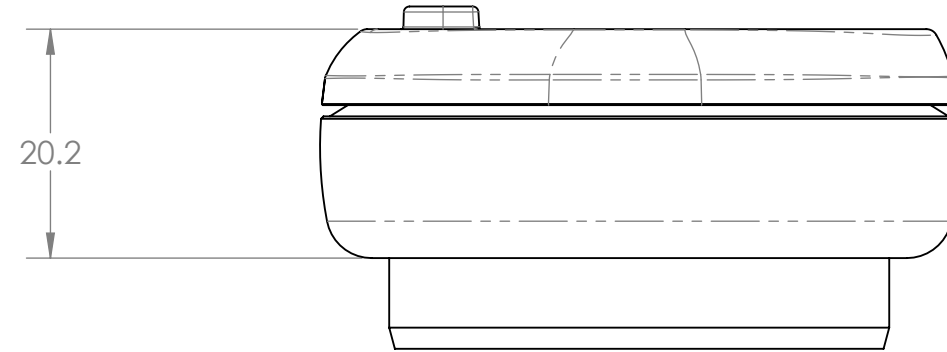
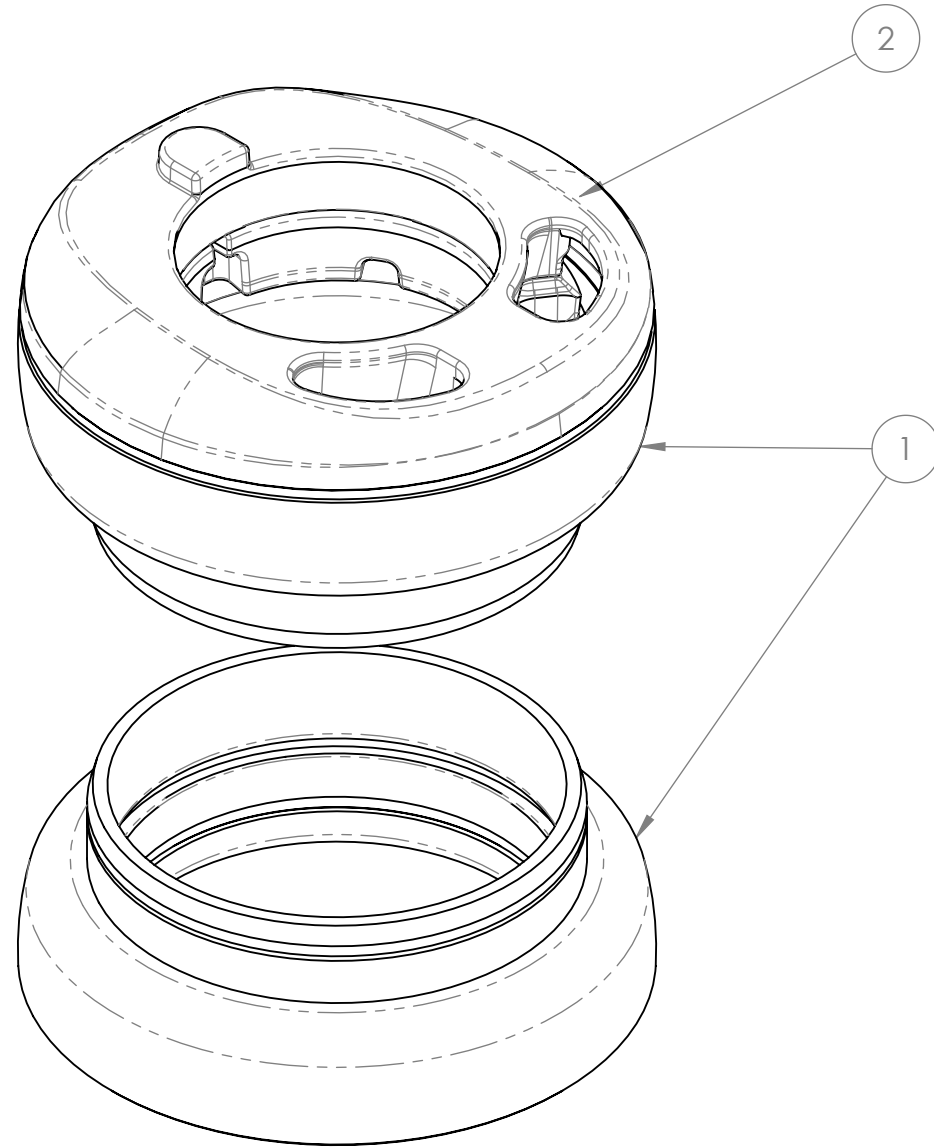

<b>PROPRIETARY AND CONFIDENTIAL</b>		NAME	DATE	
THE INFORMATION CONTAINED IN THIS DRAWING IS THE SOLE PROPERTY OF ENVE COMPOSITES INC. ANY REPRODUCTION IN PART OR AS A WHOLE WITHOUT THE WRITTEN PERMISSION OF ENVE COMPOSITES INC. IS PROHIBITED.		DRAWN S. Neperud	S. Neperud 02/02/2023	
		CHECKED		
		ENG APPR.		
		MFG APPR.		
INTERPRET GEOMETRIC TOLERANCING PER: ASME Y14.5-2009		UNLESS OTHERWISE SPECIFIED:		<b>DESCRIPTION:</b> <b>ENVE INT EC44/EC44 Headset Assembly</b>
MATERIAL		DIMENSIONS ARE IN MILLIMETRES		
FINISH		TOLERANCES: ANGULAR: ±1° UNSPECIFIED XX ±0.5 ONE PLACE DECIMAL XX.X ±0.2 TWO PLACE DECIMAL XX.XX ±0.10		
DO NOT SCALE DRAWING		SIZE <b>B</b>	DWG. NO. 100-5005-004_Complete Assembly	REV
		SCALE: 3:2	WEIGHT:	SHEET 1 OF 1