

LONEWOLF AERO CHAINGUIDE FOR ENVE

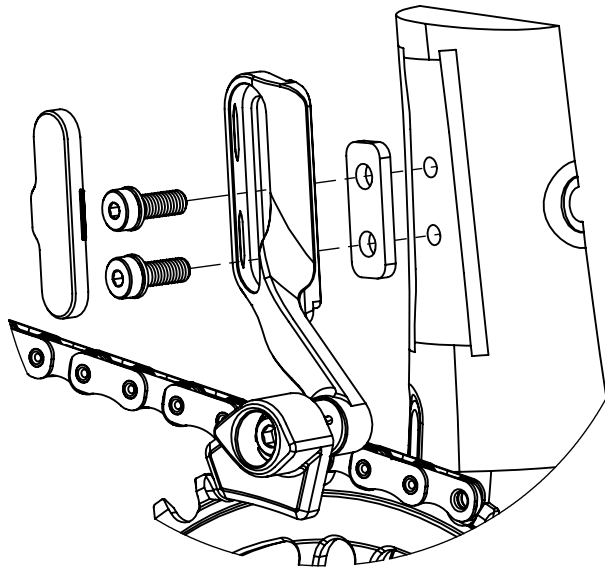

INSTALLATION INSTRUCTIONS

1. Shift the drivetrain into the largest cog on the cassette
2. Attach the guide to the frame with the two M5 bolts, making sure that the included shim is captured between the frame and guide.



Note: the shim is flat on one side and curved on the other, the curved side should face the frame. Loosely tighten both bolts so you can still move the guide around.

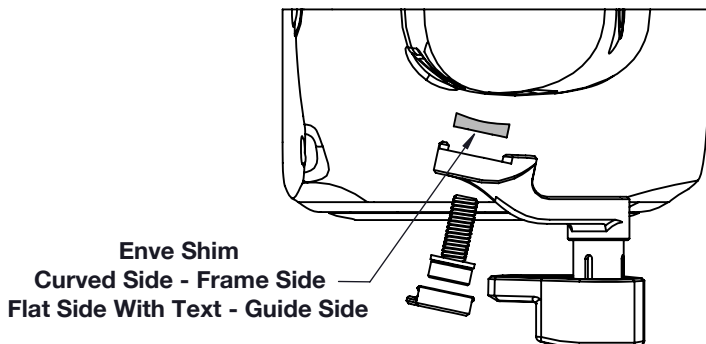

3. Loosen the expanding mandrel bolt. Position the guide so there is 1-2 mm of clearance between the chain and guide both on top and on the side of the chain. Loosely tighten both the frame bolts and the expanding mandrel bolts to hold the guide in place.
4. Tighten the frame bolts to 2Nm (the spec mandated by Enve for the front derailleur hanger bolt bosses). Install the bolt cap with the tab facing the rear wheel. It should snap into place into grooves in the guide
5. Tighten the expanding mandrel bolt to 2Nm. Do not overtighten!
6. Shift through the full range of your cassette and ensure the chain does not rub against the guide.

